



Vertex Water Features Pond and Lake Aeration

BOTTOM AERATION



AIR1Plus XL2™

The Vertex Air1 Plus XL2™ is an inexpensive solution for small, 1-2 acre ponds with irregular shapes and depths that impede normal diffuser circulation. The Air1 Plus XL2™ has the same powerful compressor system and cabinet as our standard Air 1 system but includes a valve manifold and second CoActive AirStation™ for extra circulation. This additional AirStation™ can be placed in cove areas, finger canals, behind shallow sandbars or anywhere in the water body where the pond's shape or bottom contour will limit oxygen flow from a single diffuser. The Air1 Plus XL2™ utilizes Vertex's MicronBubble™ technology allowing vital oxygen to be absorbed and poisonous gasses expelled.

Our systems have a full 2-year warranty plus a Limited Lifetime warranty against rust and corrosion on the cabinet, 5-year warranty on the AirStations™ and a 15-year warranty on BottomLine™ supply tubing.



FEATURES

AIRSTATIONXL2™

- ◆ Total pumping capacity of up to 6,700 GPM
- ◆ Four 9" flexible membrane discs with MicronBubble™ technology
- ◆ Shallow water Airstation optional for depths lower than 8'
- ◆ Self-cleaning, low maintenance
- ◆ Rugged EPDM construction with vacuum formed and sonic welded HDPE base unit
- ◆ Lipped edge prevents sinking into soft bottom sediments
- ◆ 5-year "No Questions" warranty

BROOKWOOD™ COMPRESSOR

- ◆ 2-year Vertex warranty
- ◆ Vertex SafeStart™ Technology
- ◆ UL, 115v or 230v, 35 Max PSI
- ◆ Thermal overload protection
- ◆ 1/3hp (0.25kW): low electrical costs
- ◆ 2-3 year extended duty cycle between scheduled maintenance

QUIETAIR™ CABINET

- ◆ Class "A" GFCI protection on all 115V circuits
- ◆ Powder coated aluminum for a durable attractive finish
- ◆ High capacity 140 CFM fan
- ◆ Easy access design with cam lock
- ◆ Easy plug-in connection to waterside electrical service
- ◆ Disconnect switch
- ◆ Heavy duty, light weight mounting pad included
- ◆ Sound dampening kit optional
- ◆ Limited lifetime warranty against rust

BOTTOMLINE™ TUBING

- ◆ Over-sized I.D. for high flow
- ◆ Self-weighted for easy installation
- ◆ Available in 100' and 500' increments
- ◆ 15-year Vertex warranty

BENEFITS TO THE LAKE

- ◆ High pumping rate easily penetrates stratification layers
- ◆ Circulates entire water column
- ◆ Increases oxygen levels throughout water column
- ◆ Promotes beneficial bacteria growth
- ◆ Prevents low oxygen fish kills
- ◆ Reduces nutrient levels and associated algae growth
- ◆ Oxidizes/reduces bottom muck
- ◆ Expands oxygenated habitat for improved fisheries
- ◆ Reduces aquatic midge and mosquito insect hatches
- ◆ Eliminates foul odors from undesirable dissolved gases
- ◆ Safe entry – no electricity in the water
- ◆ Extremely energy efficient

SPECIFICATIONS: AIR1PLUS XL2™ LAKE AERATION SYSTEM

BROOKWOOD™ COMPRESSOR

1/3hp (0.25kW), 115v or 230v, Single Phase piston type compressor. Built for continuous 24/7 operation and equipped with Vertex SafeStart™ technology allowing auto restart under maximum rated pressure without motor damage. Super-duty Brookwood™ compressors incorporate upgraded rotors, stators, valve plates, bearings and capacitors and are thermally protected, oil-free, and require no lubrication; just periodic cleaning of included washable air filter. Extended duty cycle is approximately 2 to 3 years for compressor maintenance, about 2 to 3 times the duty cycle of ordinary piston and rotary vane compressors. All Brookwood™ SafeStart™ compressors carry a 2-year warranty.

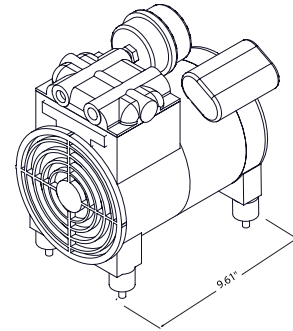

QUIETAIR™ CABINET

Cabinet is constructed of aluminum with gray electrostatically bonded powder coating. Equipped with a stamped ventilation grill, engineered fan plenum, directed exhaust and an integral cooling fan producing 140 CFM to guard against excessive compressor operating temperatures. Cabinet comes equipped with Class "A" GFCI Protection on both the compressor and fan circuits. 2-year warranty on all cabinet components including compressor, cooling fan and GFI and a Limited Lifetime warranty against cabinet rust and corrosion. Quick disconnect switch included. Side mounted muffler box and additional insulation optional for quieter operation.

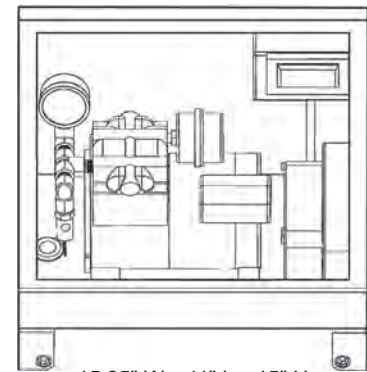

AIRSTATION XL2™ ASSEMBLY

Each CoActive AirStation™ consists of two self-cleaning, 9" diameter flexible membrane diffusers of EPDM compound with 100% rebound memory, each producing millions of fine 500 to 3000 micron bubbles. Each diffuser station is equipped with a vacuum-formed HDPE base; sonic spot-welded to provide unit integrity. Base unit has a hollow chamber design for the addition of gravel ballast and a lipped design to prevent settling into soft bottom sediments. AirStations have been independently tested and verified to provide stated pumping rates. 5-year warranty.

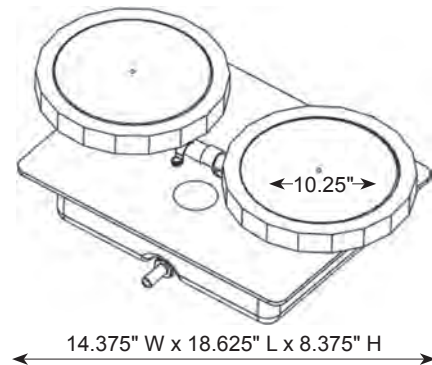

BOTTOMLINE™ SUPPLY TUBING

Self-weighted, direct burial submersible tubing for connection from compressor to diffuser stations. Tubing is flexible PVC composite construction for use with standard PVC solvent weld cement and insert fittings. Tubing has 0.58" I.D. and high wall thickness for long term durability and protection against punctures. Remains flexible in cold temperatures.

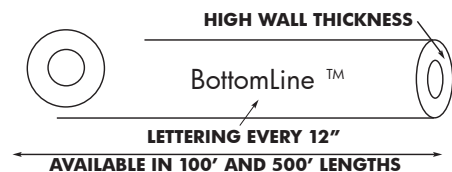

Vertex Water Features
Pond and Lake Aeration

(800) 432-4302 / Fax (954) 977-7877

www.vertexwaterfeatures.com/e-mail: info@vertexwaterfeatures.com

Install all electrical equipment in accordance with Article 682 of the National Electrical Code and all local codes. Vertex Water Features reserves the right to improve and change our designs and/or specifications of our aerators without notice or obligation.

©2012 Vertex Water Features rev.052112