



Vertex Water Features Pond and Lake Aeration

BOTTOM AERATION



HF4 XL5™

The Vertex HF4 XL5™ aeration system, designed for larger lakes and reservoirs, utilizes Vertex's latest technology to provide the most aeration for your money. Two super-duty, Brookwood™ twin cylinder HighFlow™ compressors, housed in our rustproof aluminum outdoor cabinet, providing over 10 CFM of air, feeds four of our bottom mounted XL5 AirStations™. The rising force of millions of bubbles circulates the entire water column, entraining bottom water up to the surface allowing vital oxygen to be absorbed and poisonous gases expelled. With no electricity in the water, Vertex's aeration systems are safe for most any type of water recreation.

Our systems have a full 2-year warranty plus a Limited Lifetime warranty against rust and corrosion on the cabinet, 5-year warranty on the AirStations™ and a 15-year warranty on BottomLine™ supply tubing.



FEATURES

AIRSTATIONXL5™

- ◆ Total pumping capacity of up to 35,400GPM
- ◆ Huge 5.4 ft² active lifting surface
- ◆ Four XL5 AirStations™ with five self-cleaning membrane disks each
- ◆ StableTrak™ technology stabilizes air column increasing lift velocity
- ◆ FlowControl™ technology equalizes airflow to each disc
- ◆ 5-year "No Questions" warranty

BROOKWOOD™ COMPRESSOR

- ◆ Two 3/4hp (1.12kW) Vertex HighFlow™ Series
- ◆ 11.2 Total CFM, 25 Max PSI, 230V
- ◆ Highest flow rate of any compressor in its class
- ◆ Thermal overload protection
- ◆ 2 to 4 year extended duty cycle between scheduled maintenance
- ◆ Full 2-year Vertex warranty

QUIETAIR™ CABINET

- ◆ Includes SafeStart™ technology allowing full pressure restarts
- ◆ Powder coated aluminum for a durable attractive finish
- ◆ Redundant cooling system with (2) high capacity 290 CFM cooling fans
- ◆ Easy access design with cam lock
- ◆ Easy plug-in connection to waterside electrical service
- ◆ Disconnect switch
- ◆ Heavy duty, light weight mounting pad
- ◆ Sound dampening kit optional
- ◆ Limited lifetime warranty against rust

BOTTOMLINE™ TUBING

- ◆ Over-sized I.D. for high flow
- ◆ Self-weighted for easy installation
- ◆ Available in 100' and 500' increments
- ◆ 15-year Vertex warranty

BENEFITS TO THE LAKE

- ◆ High pumping rate easily penetrates stratification layers
- ◆ Circulates entire water column
- ◆ Increases oxygen levels throughout water column
- ◆ Promotes beneficial bacteria growth
- ◆ Prevents low oxygen fish kills
- ◆ Reduces nutrient levels and associated algae growth
- ◆ Oxidizes/reduces bottom muck
- ◆ Expands oxygenated habitat for improved fisheries
- ◆ Reduces aquatic midge and mosquito insect hatches
- ◆ Eliminates foul odors from undesirable dissolved gases
- ◆ Safe entry – no electricity in the water
- ◆ Extremely energy efficient

SPECIFICATIONS: HF4 XL5™ LAKE AERATION SYSTEM

BROOKWOOD™ HIGHFLOW™ COMPRESSOR

Two 3/4hp (1.12kW), 115v or 230v, 11.2 Total CFM, 25 PSI, single phase, twin cylinder piston type compressors. 230 volt single phase 50 & 60 Hz. UR, CE, CSA listed and built for continuous 24/7 operation. Super-duty Brookwood™ HighFlow™ compressors incorporate upgraded rotors, stators, bearings and capacitors and are thermally protected, oil-free, and require no lubrication; just periodic replacement of air filter. Extended duty cycle is approximately 2 to 4 years for compressor service, about 2 to 4 times the duty cycle of ordinary piston and rotary vane compressors. All Brookwood™ HighFlow™ compressor systems carry a 2-year warranty.

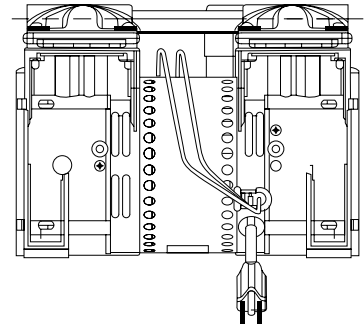

QUIETAIR™ CABINET

Enclosure comes equipped with cam lock for security, fully gasketed and constructed of aluminum with gray electrostatically-bonded powder coating to provide Limited Lifetime warranty against cabinet rust and corrosion. Enclosure furnished with stamped ventilation grill to insure forced air circulation and an integral cooling fan with thermal protection, producing 290 CFM to guard against excessive compressor operating temperatures. Equipped with Vertex SafeStart™ technology allowing auto restart under maximum rated pressure without motor damage. Cabinet provided with HDPE mounting pad. Enclosure comes equipped with class A GFCI circuit protection for all electrical components. 230 volt systems require the purchaser to provide GFCI protection on their electrical supply circuit. Quick disconnect switch included. Side mounted muffler box and additional insulation optional for quieter operation.

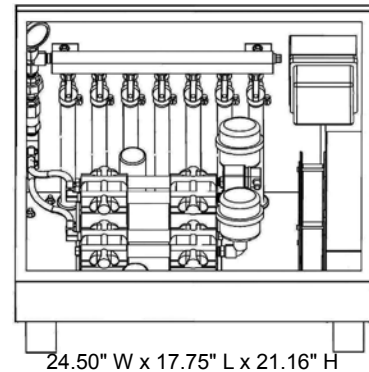

AIRSTATION XL5™ ASSEMBLY

Diffuser station consists of five self-cleaning, 9" diameter, flexible membrane diffusers of EPDM compound with 100% rebound memory, each producing millions of fine 500 to 3000 micron bubbles. Includes FlowControl™ technology that equalizes airflow to all diffusers on uneven bottoms and StableTrak™ technology which stabilizes the bubble column increasing lift velocity. Each diffuser station is equipped with a vacuum-formed HDPE base, sonic spot-welded to provide unit integrity. Base unit has a hollow chamber design for the addition of inert pea gravel ballast and a lipped design to prevent settling into soft bottom sediments.

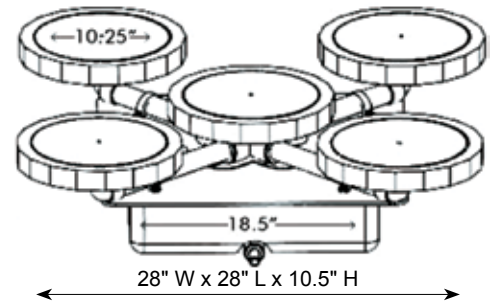

BOTTOMLINE™ SUPPLY TUBING

Self-weighted, direct burial submersible tubing for connection from compressor to diffuser stations. Tubing is flexible PVC composite construction for use with standard PVC solvent weld cement and insert fittings. Tubing has 0.58" I.D. and high wall thickness for long term durability and protection against punctures. Remains flexible in cold temperatures.

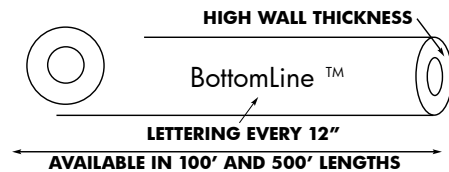

(800) 432-4302 / Fax (954) 977-7877

www.vertexwaterfeatures.com/e-mail: info@vertexwaterfeatures.com

Install all electrical equipment in accordance with Article 682 of the National Electrical Code and all local codes. Vertex Water Features reserves the right to improve and change our designs and/or specifications of our aerators without notice or obligation.

©2012 Vertex Water Features rev.042412