



Vertex Water Features Pond and Lake Aeration

BOTTOM AERATION



HF7 XL2™

The all new Vertex HF7 XL2 pond aerator is a superefficient, affordable system designed to maximize aeration in 6-9 acre ponds depending on shape, slope, oxygen demand, and other factors. Two 3/4hp (1.12kW) super-duty Brookwood™ twin cylinder HighFlow™ series compressors, housed in our rustproof aluminum outdoor cabinet, feed seven bottom mounted CoActive AirStations™ utilizing Vertex's MicronBubble™ technology. The rising force of millions of bubbles circulates the entire water column, entraining bottom water up to the surface allowing vital oxygen to be absorbed and poisonous gasses expelled. With no electricity in the water, Vertex's aeration systems are safe for most any type of water recreation.

Our systems have a full 2-year warranty plus a Limited Lifetime warranty against rust and corrosion on the cabinet, 5-year warranty on the AirStations™ and a 15-year warranty on BottomLine™ supply tubing.



FEATURES

AIRSTATIONXL2™

- ◆ Total pumping capacity of up to 27,100 GPM
- ◆ Fourteen 9" flexible membrane discs with MicronBubble™ technology
- ◆ Shallow water Airstation optional for depths lower than 8'
- ◆ Self-cleaning, low maintenance
- ◆ Rugged EPDM construction with vacuum formed and sonic welded HDPE base unit
- ◆ Lipped edge prevents sinking into soft bottom sediments
- ◆ 5-year "No Questions" warranty

BROOKWOOD™ COMPRESSOR

- ◆ 2-year Vertex warranty
- ◆ Vertex SafeStart™ Technology
- ◆ UL, 115v or 230v, 25 Max PSI
- ◆ Thermal overload protection
- ◆ (2)3/4hp (1.12kW): low electrical costs
- ◆ 2-3 year extended duty cycle between scheduled maintenance

QUIETAIR™ CABINET

- ◆ Class "A" GFCI protection on all 115v circuits
- ◆ Powder coated aluminum for a durable attractive finish
- ◆ Two high capacity 290 CFM fan
- ◆ Easy access design with cam lock
- ◆ Easy plug-in connection to waterside electrical service
- ◆ Disconnect switch
- ◆ Heavy duty, light weight mounting pad included
- ◆ Sound dampening kit optional
- ◆ Limited lifetime warranty against rust

BOTTOMLINE™ TUBING

- ◆ Over-sized I.D. for high flow
- ◆ Self-weighted for easy installation
- ◆ Available in 100' and 500' increments
- ◆ 15-year Vertex warranty

BENEFITS TO THE LAKE

- ◆ High pumping rate easily penetrates stratification layers
- ◆ Circulates entire water column
- ◆ Increases oxygen levels throughout water column
- ◆ Promotes beneficial bacteria growth
- ◆ Prevents low oxygen fish kills
- ◆ Reduces nutrient levels and associated algae growth
- ◆ Oxidizes/reduces bottom muck
- ◆ Expands oxygenated habitat for improved fisheries
- ◆ Reduces aquatic midge and mosquito insect hatches
- ◆ Eliminates foul odors from undesirable dissolved gases
- ◆ Safe entry – no electricity in the water
- ◆ Extremely energy efficient

SPECIFICATIONS: HF7 XL2™ LAKE AERATION SYSTEM

BROOKWOOD™ COMPRESSOR

Two 3/4hp (0.75kW), 115v or 230v, Single Phase piston type compressor. Built for continuous 24/7 operation and equipped with Vertex SafeStart™ technology allowing auto restart under maximum rated pressure without motor damage. Super-duty Brookwood™ compressors incorporate upgraded rotors, stators, valve plates, bearings and capacitors and are thermally protected, oil-free, and require no lubrication; just periodic cleaning of included washable air filter. Extended duty cycle is approximately 2-3 years for compressor maintenance, about 2 to 3 times the duty cycle of ordinary piston and rotary vane compressors. All Brookwood™ SafeStart™ compressors carry a 2-year warranty.

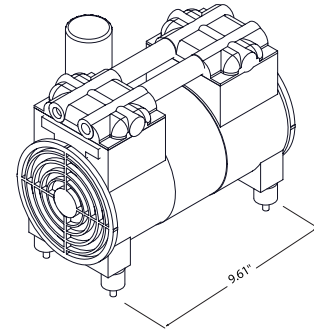

QUIETAIR™ CABINET

Enclosure comes equipped with cam lock for security, fully gasketed and constructed of aluminum with gray electrostatically-bonded powder coating to provide Limited Lifetime warranty against cabinet rust and corrosion. Enclosure furnished with stamped ventilation grills to insure forced air circulation and an integral cooling fan with thermal protection, producing 290 CFM to guard against excessive compressor operating temperatures. Cabinet provided with HDPE mounting pad. Enclosure comes with class a GFCI protection on both the compressor and fan circuits. Quick disconnect switch included. Side mounted muffler box and additional insulation optional for quieter operation.

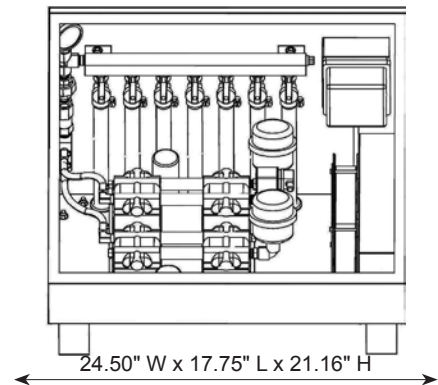

AIRSTATION XL2™ ASSEMBLY

Diffuser station consisting of two self-cleaning, 9" diameter, flexible membrane diffusers of EPDM compound with 100% rebound memory, each producing millions of fine 500 to 3000 micron bubbles – the majority 500 to 1000 microns. Each diffuser station is equipped with vacuum formed HDPE base, sonic spot-welded to provide unit integrity. Base unit is made of hollow chamber design for the addition of inert pea gravel ballast and have lipped design to prevent settling into soft bottom sediments. AIRSTATION™ is designed with adjustable diffuser riser to accommodate any site requirements.

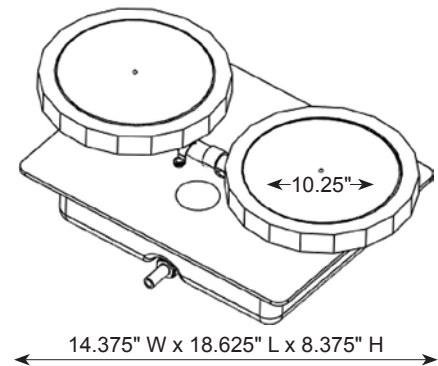

BOTTOMLINE™ SUPPLY TUBING

Self-weighted, direct burial submersible tubing for connection from compressor to diffuser stations. Tubing is flexible PVC composite construction for use with standard PVC solvent weld cement and insert fittings. Tubing has 0.58" I.D. and high wall thickness for long term durability and protection against punctures. Remains flexible in cold temperatures.

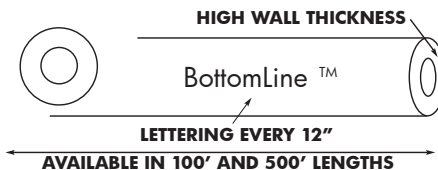

(800) 432-4302 / Fax (954) 977-7877

www.vertexwaterfeatures.com/e-mail: info@vertexwaterfeatures.com

Install all electrical equipment in accordance with Article 682 of the National Electrical Code and all local codes. Vertex Water Features reserves the right to improve and change our designs and/or specifications of our aerators without notice or obligation.

©2012 Vertex Water Features rev.052112